

SECTION **FL**
FUEL SYSTEM

CONTENTS

PRECAUTIONS	2	INSPECTION AFTER INSTALLATION	9	F
Precautions for Battery Service	2	Components	9	
PREPARATION	3	Disassembly and Assembly	9	
Commercial Service Tools	3	DISASSEMBLY	9	G
FUEL SYSTEM	4	ASSEMBLY	10	
Checking Fuel Lines	4	FUEL TANK	11	
General Precautions	4	Components	11	H
FUEL LEVEL SENSOR UNIT, FUEL FILTER AND		Removal and Installation	11	
FUEL PUMP ASSEMBLY	5	REMOVAL	11	
Components	5	INSTALLATION	12	I
Removal and Installation	5	INSPECTION AFTER INSTALLATION	12	
REMOVAL	5	SERVICE DATA AND SPECIFICATIONS (SDS)	13	
INSTALLATION	7	Standard and Limit	13	J

PRECAUTIONS

PRECAUTIONS

PFP:00001

Precautions for Battery Service

NBS0012T

Before disconnecting the battery, lower both the driver and passenger windows. This will prevent any interference between the window edge and the vehicle when the door is opened/closed. During normal operation, the window slightly raises and lowers automatically to prevent any window to vehicle interference. The automatic window function will not work with the battery disconnected.

PREPARATION

PREPARATION

PFP:00002

Commercial Service Tools

NBS0012U

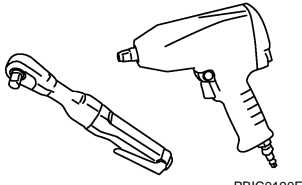
Tool name	Description
<p data-bbox="140 310 252 336">Power tool</p>  <p data-bbox="837 512 909 532">PBIC0190E</p>	<p data-bbox="997 310 1252 336">Loosening bolts and nuts</p>

A
FL
C
D
E
F
G
H
I
J
K
L
M

FUEL SYSTEM

PFP:17503

Checking Fuel Lines

NBS0012V

Inspect fuel lines, fuel filler cap and fuel tank for improper attachment, leaks, cracks, damage, loose connections, chafing or deterioration.

If necessary, repair or replace damaged parts.

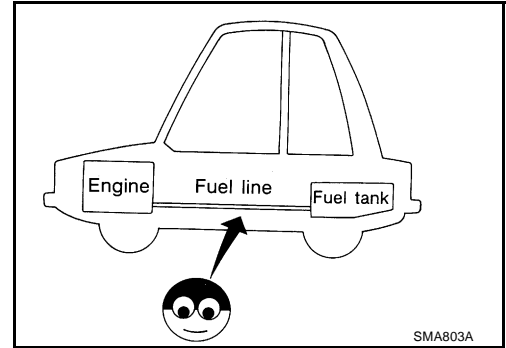

General Precautions

NBS0012W

WARNING:

When replacing fuel line parts, be sure to observe the following.

- Put a "CAUTION: FLAMMABLE" sign in the workshop.
- Be sure to work in a well ventilated area and furnish workshop with a CO₂ fire extinguisher.
- Do not smoke while servicing fuel system. Keep open flames and sparks away from the work area.

CAUTION:

- Use gasoline required by the regulations for octane number. Refer to [GI-6, "Precautions for Fuel \(Unleaded Premium Gasoline Required\)"](#).
- Before removing fuel line parts, carry out the following procedures:
 - Put drained fuel in an explosion-proof container and put the lid on securely. Keep the container in safe area.
 - Release fuel pressure from the fuel lines. Refer to [EC-81, "FUEL PRESSURE RELEASE"](#).
 - Disconnect negative battery terminal.
- Always replace O-ring and clamps with new ones.
- Do not kink or twist tubes when they are being installed.
- Do not tighten hose clamps excessively to avoid damaging hoses.
- After connecting fuel tube quick connectors, make sure quick connectors are secure. Ensure that connector and resin tube do not contact any adjacent parts.
- After installing tubes, make sure there is no fuel leakage at connections in the following steps.
 - Apply fuel pressure to fuel lines with turning ignition switch "ON" (with engine stopped). Then check for fuel leaks at connections.
 - Start engine and rev it up and check for fuel leaks at connections.
- Use only a genuine NISSAN fuel filler cap as a replacement. If an incorrect fuel filler cap is used, the "MIL" may come on.
- For servicing "Evaporative Emission System" parts, refer to [EC-32, "EVAPORATIVE EMISSION SYSTEM"](#).
- For servicing "On Board Refueling Vapor Recovery (ORVR)" parts, refer to [EC-39, "ON BOARD REFUELING VAPOR RECOVERY \(ORVR\)"](#).

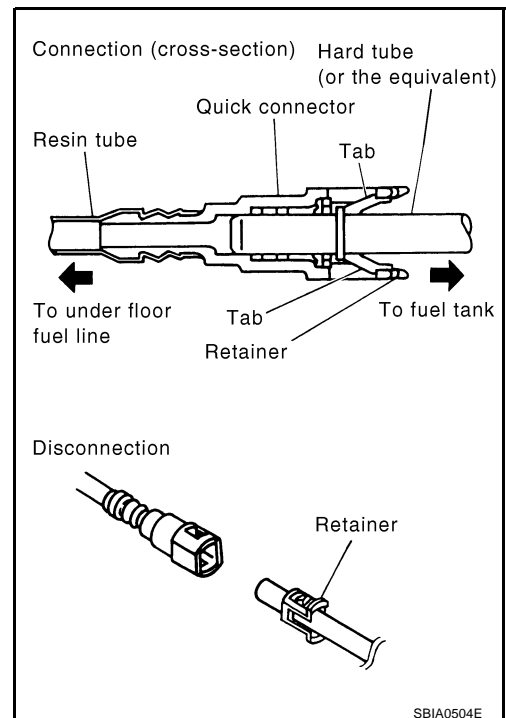

FUEL LEVEL SENSOR UNIT, FUEL FILTER AND FUEL PUMP ASSEMBLY

FUEL LEVEL SENSOR UNIT, FUEL FILTER AND FUEL PUMP ASSEMBLY PFP:17042

Components

NBS0012X

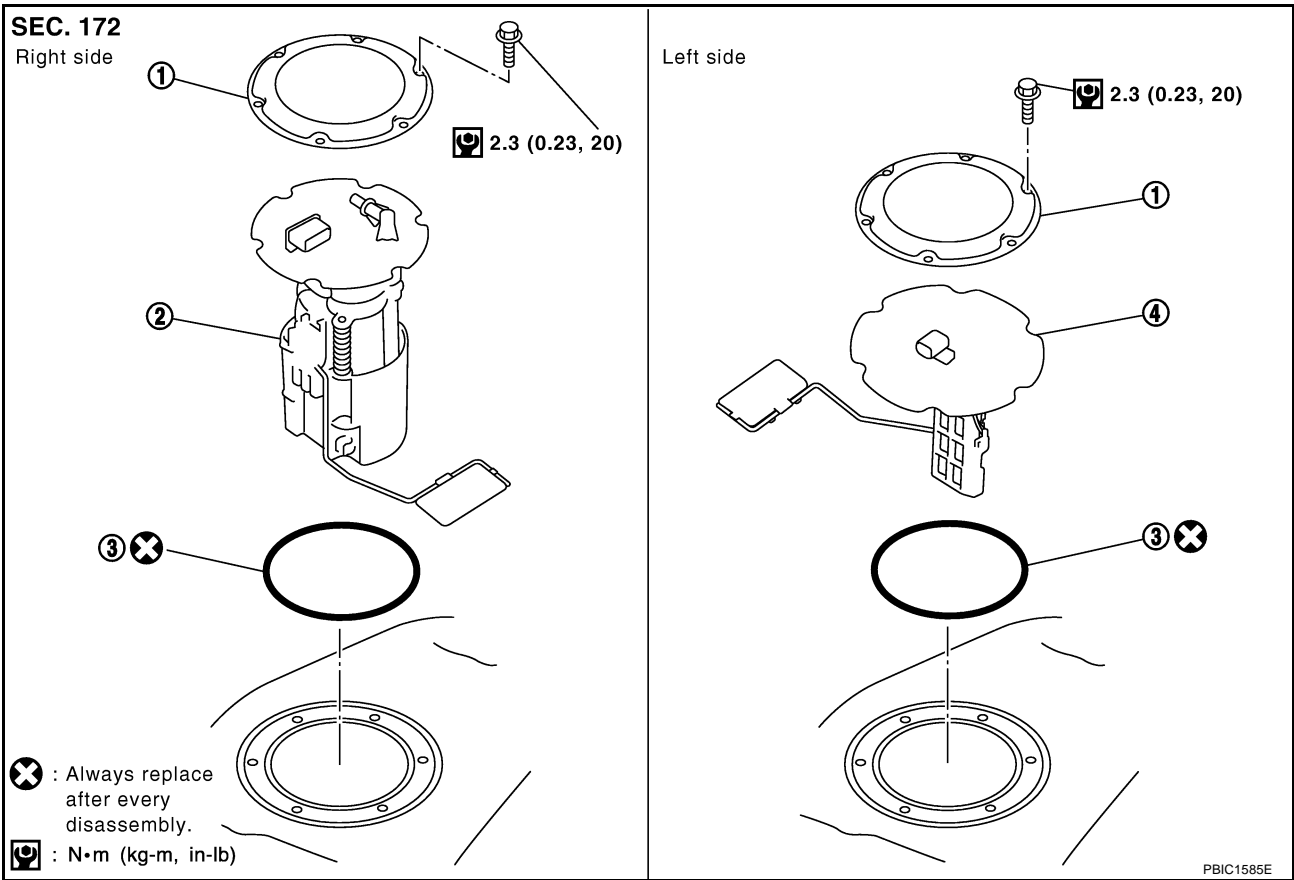

1. Retainer
2. Main fuel level sensor unit, fuel filter - and fuel pump assembly
3. O-ring
4. Sub fuel level sensor unit

Removal and Installation

REMOVAL

WARNING:

Be sure to read "General Precautions" when working on the fuel system. Refer to [FL-4, "General Precautions"](#).

1. Check fuel level on fuel gauge. If fuel gauge indicates more than the level as shown in the figure (full or almost full), drain fuel from fuel tank until gauge indicates level as shown in the figure or below.

NOTE:

Because fuel will be spilled when removing main and sub fuel level sensor units for the top of the fuel is above the main and sub fuel level sensor units installation surface.

- As a guide, fuel level becomes the position as shown in the figure or below when approximately 20 ℓ (5-1/4 US gal, 4-3/8 Imp gal) of fuel are drained from fuel tank.
 - In a case that fuel pump does not operate, perform the following procedure.
 - a. Insert hose of less than 25 mm (0.98 in) in diameter into fuel filler tube through fuel filler opening to draw fuel from fuel filler tube.
 - b. Disconnect fuel filler hose from fuel filler tube. Refer to [FL-11, "FUEL TANK"](#).
 - c. Insert fuel tube into fuel tank through fuel filler hose to draw fuel from fuel tank.
2. Release the fuel pressure from the fuel lines. Refer to [EC-81, "FUEL PRESSURE RELEASE"](#).

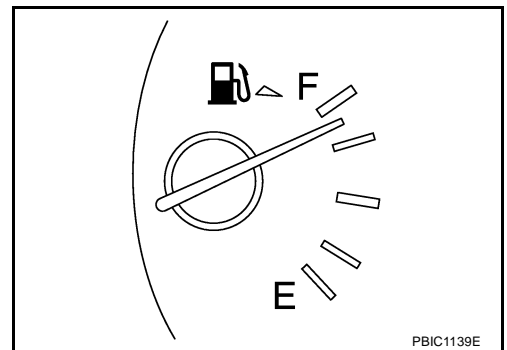

FUEL LEVEL SENSOR UNIT, FUEL FILTER AND FUEL PUMP ASSEMBLY

3. Open fuel filler lid.
4. Open filler cap and release the pressure inside fuel tank.
5. Remove rear seat cushion. Refer to [SE-140, "REAR SEAT"](#).
6. Peel off floor carpet, then remove inspection hole cover for main and sub fuel level sensor units by turning clips clockwise by 90 degrees.

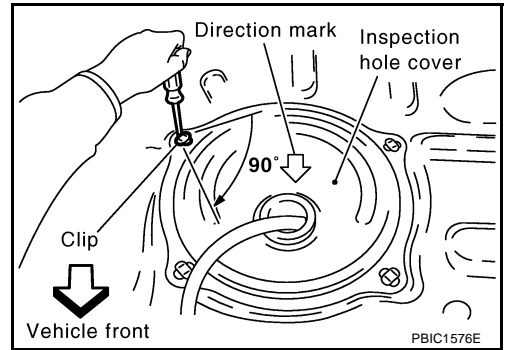

7. Disconnect harness connector and fuel feed tube.

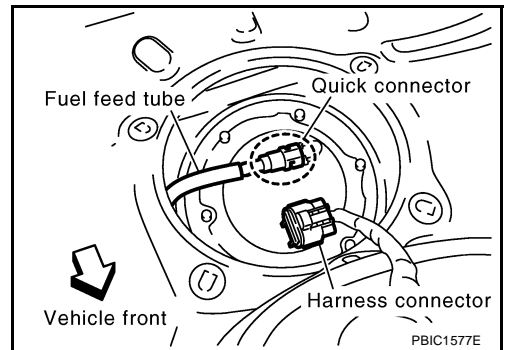

Disconnect quick connector as follows:

- Hold the sides of connector, push in tabs and pull out tube.
- If quick connector sticks to tube of main fuel level sensor unit, push and pull quick connector several times until they start to move. Then disconnect them by pulling.

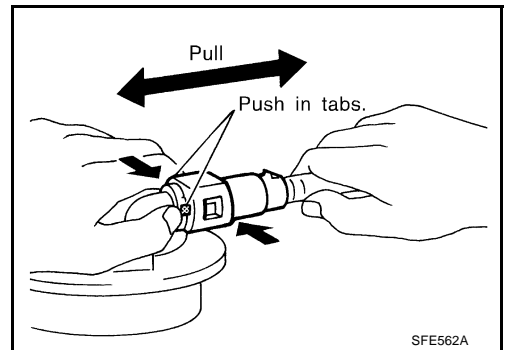

FUEL LEVEL SENSOR UNIT, FUEL FILTER AND FUEL PUMP ASSEMBLY

CAUTION:

- Quick connector can be disconnected when the tabs are completely depressed. Do not twist it more than necessary.
- Do not use any tools to disconnected quick connector.
- Keep resin tube away from heat. Be especially careful when welding near the resin tube.
- Prevent acid liquid such as battery electrolyte, etc. from getting on resin tube.
- Do not bend or twist resin tube during installation and disconnection.
- Do not remove the remaining retainer on hard tube (or the equivalent) except when resin tube or retainer is replaced.
- When resin tube or hard tube (or the equivalent) is replaced, also replace retainer with new one.

Retainer color: White

- To keep the connecting portion clean and to avoid damage and foreign materials, cover them completely with plastic bags or something similar.

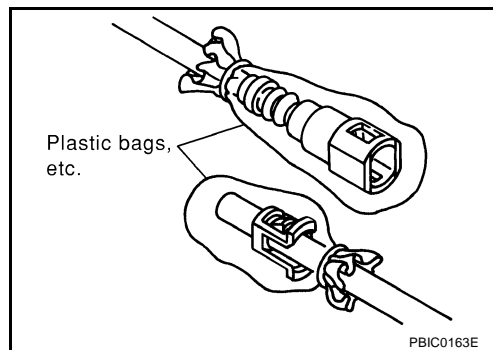
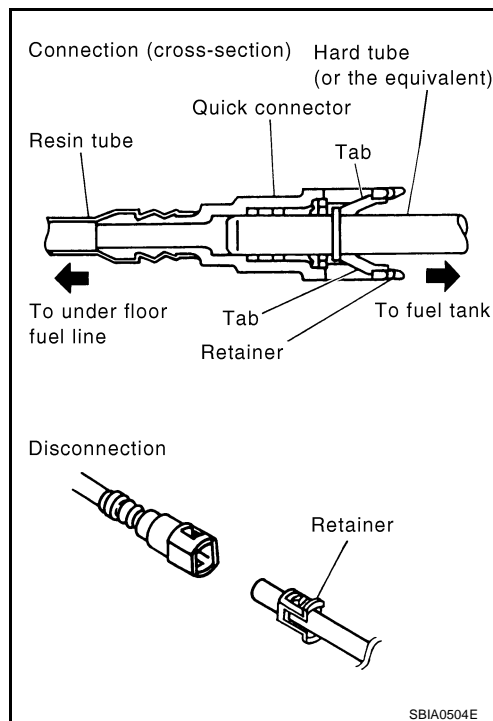

8. Remove main fuel level sensor unit, fuel filter and fuel pump assembly, and sub fuel level sensor unit as follows:

CAUTION:

- Do not bend float arm during removal.
- Avoid impacts such as falling when handling components.

- a. Removal of main fuel level sensor unit, fuel filter and fuel pump assembly:
 - i. Remove retainer.
 - ii. Raise main fuel level sensor unit, fuel filter and fuel pump assembly, and using snap ring pliers, remove fuel hose connector.

CAUTION:

Be careful not to damage fuel hose connector by expanding them excessively.

- b. Removal of sub fuel level sensor unit:
 - i. Remove retainer.
 - ii. Raise and release sub fuel level sensor unit to remove.

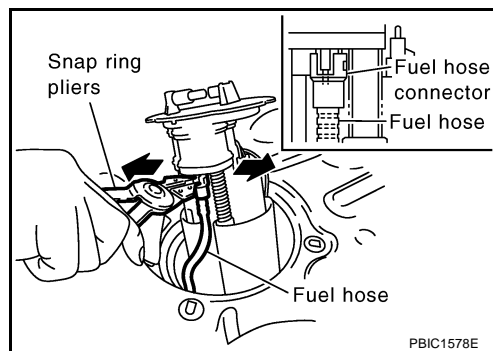

INSTALLATION

Note the following, and install in the reverse order of removal.

FUEL LEVEL SENSOR UNIT, FUEL FILTER AND FUEL PUMP ASSEMBLY

Main and Sub Fuel Level Sensor Unit

- When installing fuel hose connector insert them fully until a click sound of full stopper engagement is heard.

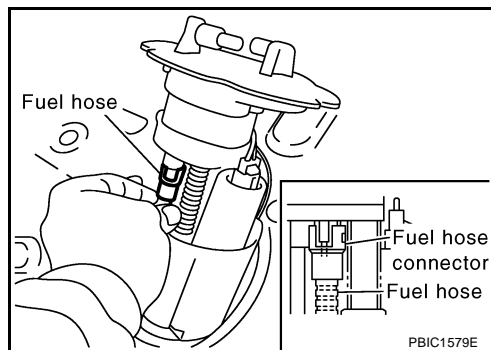

- Face main and sub fuel level sensor units as shown in the figure, and install them with the knock pin on back aligned with pin hole on fuel tank.

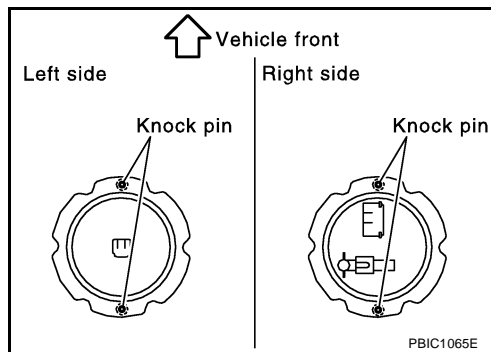

- Install retainer so that its notch becomes parallel with the notch on fuel tank.

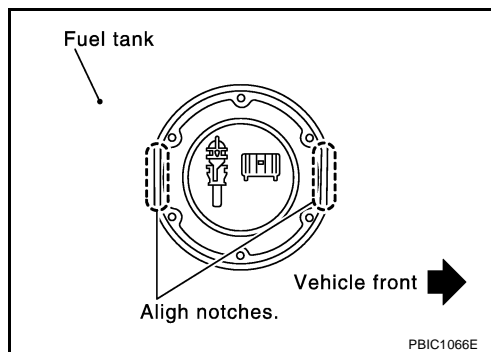

- Tighten retainer mounting bolts evenly.

Quick Connector

Connect quick connector as follows:

1. Check the connection for damage or any foreign materials.
2. Align the connector with the tube, then insert the connector straight into the tube until a click sound is heard.
3. After connecting, make sure that the connection is secure by following method.
 - Pull the tube and the connector to make sure they are securely connected.
 - Visually confirm that the two retainer tabs are connected to the connector.

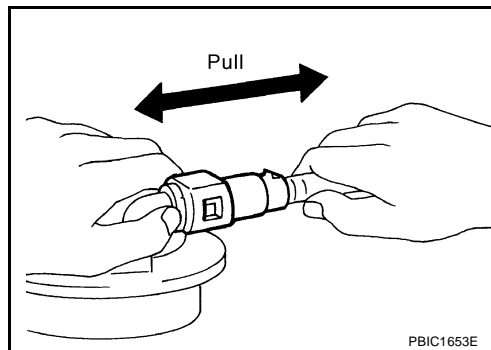

FUEL LEVEL SENSOR UNIT, FUEL FILTER AND FUEL PUMP ASSEMBLY

INSPECTION AFTER INSTALLATION

Use the following procedure to check for fuel leaks.

1. Turn ignition switch "ON" (with engine stopped), then check connections for leaks by applying fuel pressure to fuel piping.
2. Start engine and let it idle and make sure there are no fuel leaks at the fuel system connections.

Components

NBS0012Z

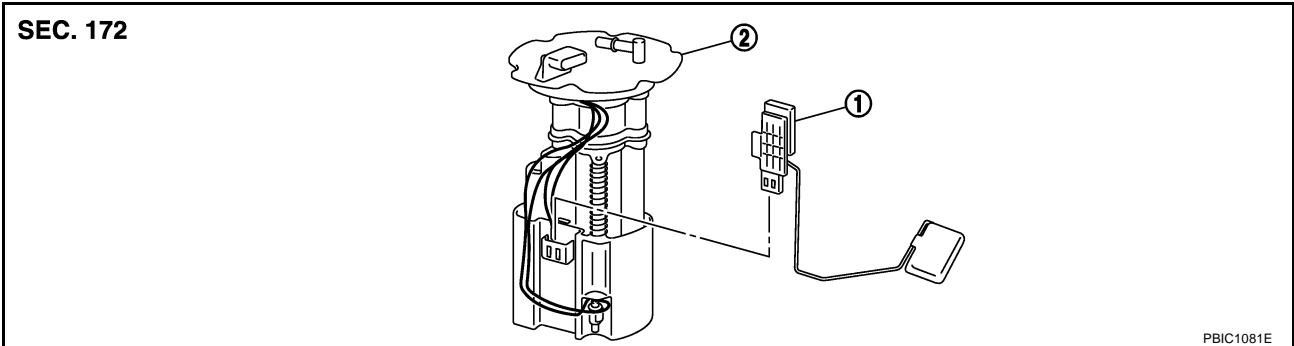

1. Fuel level sensor unit
2. Fuel filter and fuel pump assembly

Disassembly and Assembly

NBS00130

CAUTION:

Sub fuel level sensor unit cannot be disassembled and should be replaced as a unit.

DISASSEMBLY

Remove fuel level sensor unit as follows.

1. Disconnect harness connector.
 - Hold connector by fingers and pull it out, because there is no stopper release tab.

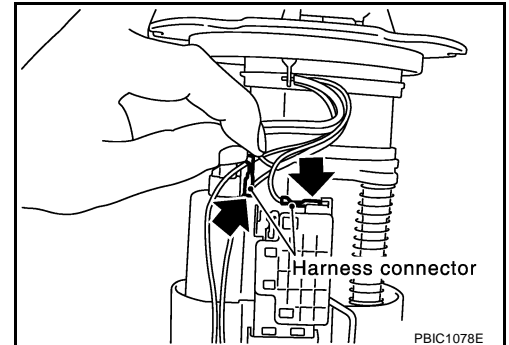

2. Using suitable tool, pull up tabs points as shown in the figure (two points) to release the lock.

CAUTION:

Be careful not to damage it.

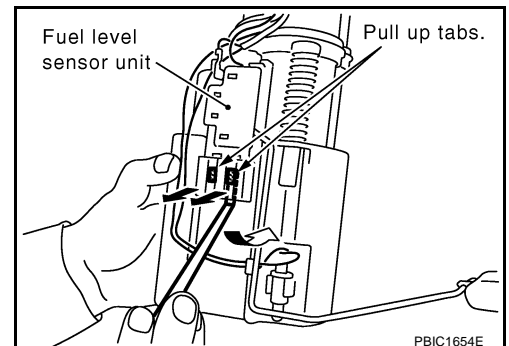

A
FL
C
D
E
F
G
H
I
J
K
L
M

FUEL LEVEL SENSOR UNIT, FUEL FILTER AND FUEL PUMP ASSEMBLY

3. After fixing tabs are disengaged, slide fuel level sensor unit out in direction shown by the arrow.

CAUTION:

Do not disassemble fuel filter and fuel pump assembly.

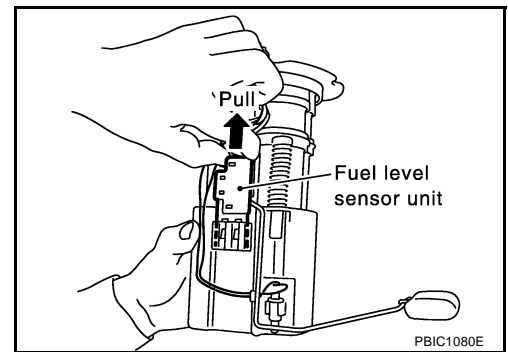

ASSEMBLY

1. Check for damage of fuel level sensor unit installation position on the side of fuel filter and fuel pump assembly.
2. Slide fuel level sensor unit until it aligns to installation groove, then insert it until stop.
 - After inserting, apply force in reverse direction (removal direction) to ensure it cannot be pulled out.
3. Connect harness connector.
 - Securely insert harness connector until it stops.

FUEL TANK

FUEL TANK Components

PFP:17202

NBS00131

A

FL

C

D

E

F

G

H

I

J

K

L

M

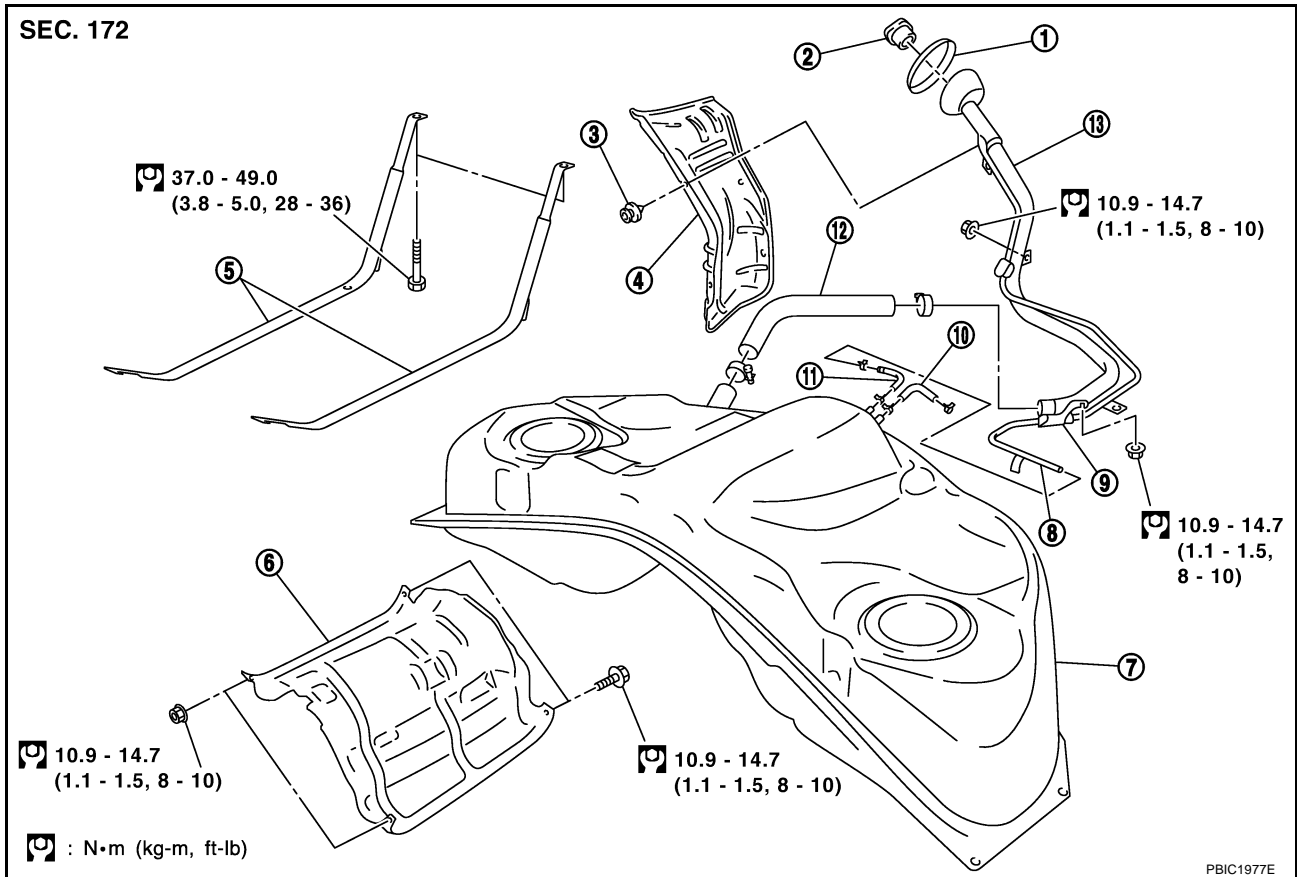

- | | | |
|-------------------------------|----------------------------|------------------------|
| 1. Grommet | 2. Fuel filler cap | 3. Clip |
| 4. Fuel filler tube protector | 5. Fuel tank mounting band | 6. Fuel tank protector |
| 7. Fuel tank | 8. Vent tube | 9. Vent hose |
| 10. EVAP hose | 11. Vent hose | 12. Fuel filler hose |
| 13. Fuel filler tube | | |

Removal and Installation REMOVAL

NBS00132

WARNING:

Be sure to read "General Precautions" when working on the fuel system. Refer to [FL-4, "General Precautions"](#).

- Drain fuel from fuel tank if necessary. Refer to [FL-5, "REMOVAL"](#).
 - Perform work on level place.
1. Perform steps 2 to 7 of "REMOVAL" in "FUEL LEVEL SENSOR UNIT, FUEL FILTER AND FUEL PUMP ASSEMBLY" on main and sub fuel level sensor units. Refer to [FL-5, "REMOVAL"](#).
 2. Remove tunnel stay. Refer to [RSU-5, "REAR SUSPENSION ASSEMBLY"](#).
 3. Remove exhaust front tube, center muffler and main muffler. Refer to [EX-3, "EXHAUST SYSTEM"](#).
 4. Remove propeller shaft. Refer to [PR-4, "REAR PROPELLER SHAFT"](#).
 5. Remove parking rear brake cables. Refer to [PB-6, "PARKING BRAKE CONTROL"](#).
 6. Compress coil spring and remove coil spring.
 7. Remove rear suspension assembly.
 8. Remove fuel tank protector.

FUEL TANK

9. Disconnect fuel filler hose, vent hose and EVAP hoses at fuel tank side.

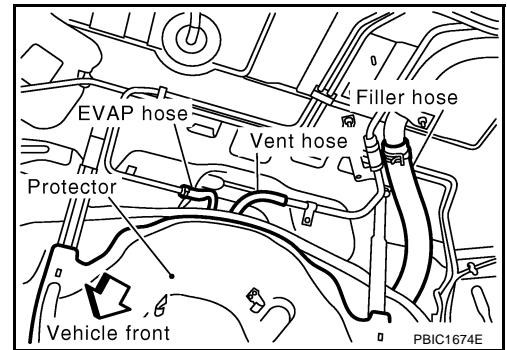

10. Remove fuel tank mounting band bolts while supporting fuel tank.

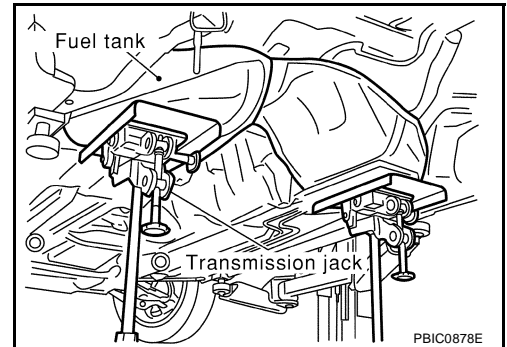

11. Remove fuel tank.

INSTALLATION

Note the following, and install in the reverse order of removal.

- Surely clamp fuel hoses and insert hose to the length below.

Fuel filler hose : 35 mm (1.38 in)

The other hoses : 25 mm (0.98 in)

- Be sure hose clamp is not placed on swelled area of fuel tube.
- Tighten fuel hose clamp so that the distance between its lugs becomes to the following.

Fuel tank side : 8 - 12 mm (0.31 - 0.47 in)

Fuel filler tube side : 5.7 - 9.7 mm (0.22 - 0.38 in)

- To connect quick connector, refer to [FL-8, "Quick Connector"](#).

INSPECTION AFTER INSTALLATION

Use the following procedure to check for fuel leaks.

1. Turn ignition switch "ON" (with engine stopped), and check connections for leakage by applying fuel pressure to fuel piping.
2. Start engine and check for fuel leaks at the fuel system tube and hose connections.

SERVICE DATA AND SPECIFICATIONS (SDS)

SERVICE DATA AND SPECIFICATIONS (SDS)

PFP:00030

Standard and Limit

NBS00133

Fuel tank capacity	Approx. 76 ℓ (20 US gal, 16-5/8 Imp gal)
Fuel recommendation	Refer to GI-6

A

FL

C

D

E

F

G

H

I

J

K

L

M

SERVICE DATA AND SPECIFICATIONS (SDS)
